



MORE INFO

CLASSICO 4 PIZZE

Data Sheets - Scheda Tecnica



Weight Peso	118 kg 260 lbs	Materials Materiali	Stainless Steel, iron sheet, Ceramic fiber Acciaio inox, lamiera ferro, Fibroceramica
Cooking floor Piano Cottura	90 x 60 cm 35 x 24 in	Type of refractory Tipo di refrattario	Alumina silicate HeatKeeper™ Firebrick Tavella HeatKeeper™ silico-alluminoso
Max oven temperature Temperatura massima	500°C 1000°F	Recommended fuel Combustibile consigliato	WOOD - Max 2 in diam. logs. trimmings LEGNA - Cocchi diametro Max 5 cm potature
Heating time Minuti per scaldare	30'	Minimum flue draught Tiraggio minimo	11 Pa
Pizza capacity Numero Pizze	4 Pizza Ø30cm	Flue smokes mass flow Flusso volumetrico fumi	49.6 g/s
Rated charge Carica Nominale	8.3 kg/h 18.3 lbs/h	Average consumption Consumo Medio	2.4 kg/h 5.2 lbs/h
Smoke temperature Temperatura fumi	400°C 752°F	CO emission at 13% O₂ Emissioni CO al 13% O ₂	0.35% 4444 mg/Nm³



made in Italy

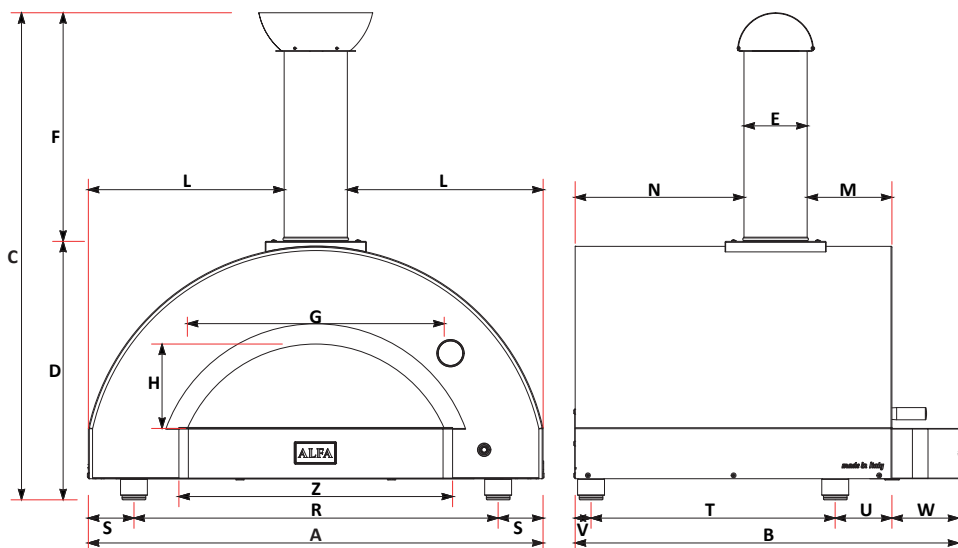

	cm	inch		cm	inch
A	108	42,5	O	47,6	18,7
B	91	35,8	P	27,6	10,9
C	115,7	45,6	Q	54	21,3
D	61,4	24,2	R	86,5	34,1
E	15	5,9	S	10,8	4,3
F	54,2	21,3	T	58	22,8
G	61	24,0	U	13,5	5,3
H	20	7,9	V	3,8	1,5
L	46,5	18,3	W	15,9	6,3
M	20,1	7,9	Z	65	25,6
N	39,9	15,7			

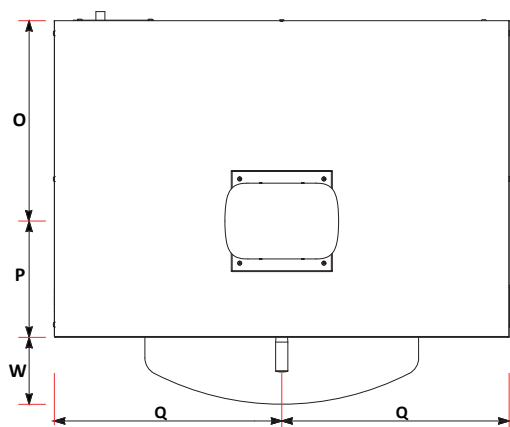

PACKAGING				
DIMENSIONE IMBALLO				
	Width Larghezza	Depth Profondità	Height Altezza	Weight Peso
cm	114	101	72,5	kg 135
inch	45	39,8	28,5	lbs 297,6

Description Descrizione	Code Codice
Chimney cap Comignolo	A CMG-1-008
Chimney Canna fumaria	B TI150_480_SAT
Door Sportello	C SPT-1-008
Flange Flangia	D FLG-2-007
External shell Carter esterno	E CRT-1-024
Thermometer Termometro	F YT63-135
Red bricks 30x20 cm Mattoni 30x20 cm	G RRA3020
Feet (n.4) Piedini	H SETPIE-M10X20
Logo Alfa (v1.0)	I D14PLAC-ALFA

